

## DISTRIBUTED GENERATION PLANNING VIA STRENGTH PARETO MULTIOBJECTIVE OPTIMIZATION APPROACH

S. Jalilzadeh M. Darabian M. Azari

*Electrical Engineering Department, Zanjan University, Zanjan, Iran  
jalilzadeh@znu.ac.ir, m.darabian@znu.ac.ir, m.azari@znu.ac.ir*

**Abstract-** Owing to the incremental demands for electrical energy, distributed generation (DG) sources are becoming more important in distribution systems. Locations and capacities of DG sources have profoundly impacted on the system losses in a distribution network. In this paper, a novel Strength Pareto Evolutionary Algorithm (SPEA) is represented for optimal location and sizing of DG on distribution systems. The objective is minimizing network power losses, better voltage regulation and improves the voltage stability within the security constraints in radial distribution systems. Two different systems, 33 and 69 bus systems, are used to demonstrate the effectiveness of the proposed methodology. The results are compared with other evolutionary methods like GA and COA through some performance indices to indicate its flexibility.

**Keywords:** Distributed generation (DG), Losses, Optimal planning, Strength Pareto Evolutionary Algorithm (SPEA), Chaotic Algorithm, Chaotic Optimization Algorithm (COA), Genetic Algorithm (GA).

### I. INTRODUCTION

Distributed generation (DG) refers to the use of smaller-sized grid-connected generators, usually 10 MW or less, in electric power distribution systems. Since the generators are distributed and closer to the loads, DG potentially offers increased reliability and security of the electricity supply. DG technologies include reciprocating diesel engines, internal combustion gas turbines, and emerging clean power generation technologies such as fuel cells, microturbines, photovoltaic, and wind turbines [1]. Including distributed generation in distribution systems often requires in-depth analysis and planning. They usually include technical, economical, regulatory, and possibly environmental challenges. As in the majority of planning process, a cost function is normally constructed to represent the overall operating and investment costs of a distribution planning area [2]. Engineering parameters such as capacity, reliability, power losses, voltage regulation, power quality, load demand, to mention just a few are converted into costs associated with the operation and investment.

There is several cost functions based on various planning scenarios. A set of constraints functions are also assembled. They include voltage limits, available short-circuit capacity, overcurrent protective requirements, and so on. Cost functions and their constraints are solved using various optimization methods. Different approaches have been represented to find the optimal location and size of DG units in the network. A multi-objective optimization approach considering losses reduction and voltage profile improvement for DG allocation using GA is proposed in [3]. A fuzzy multi-objective optimization considering voltage drop, system losses, short-circuit capacity and system operation cost for DG allocation is proposed for a small distribution system in [4].

In [5], a TS method is presented to size the DG optimally, as well as the reactive sources within the distribution system. Optimal placement problem is formulated as an optimization problem with an objective function including the total cost of active power losses, line loading and the cost of adding reactive sources. An ant colony optimization method as an optimization tool is proposed for solving the DG sizing and location problems [6]. Minimized objective function for used method is the global network cost. In [7], an analytical technique is proposed for optimally allocating DG units in a radial distribution system that minimizes power losses. The proposed technique considered different types of load profiles with varying time loads and DG output while also taking into account technical constraints, such as feeder capacity limits and voltage profile.

In [8], an analytical approach to determine the optimal DG sizing based on power loss sensitivity analysis. Various strategies to reduce the atmospheric emissions have been proposed and discussed. In [9] use fast Newton-Raphson algorithm, linear programming [10]. The approach is based on minimizing the distribution system power losses.

In this paper a novel algorithm is proposed to find optimal location and size of DG units in distribution networks. The DG planning problem is converted to an optimization problem with the multi objective function including the minimum network power losses, the desired voltage regulation and the desired voltage stability of the distribution system which is solved by the SPEA

algorithm. The validity of the proposed approach is confirmed on 33 bus and 69 bus test systems under different operating conditions. A comparative analysis is made between other methods such as GA and COA<sup>1)</sup> through some performance indices to illustrate its strong performance. This paper is organized as follows: Section II sets out the problem formulation, Section III presents proposed solution method for solving the problem, the application of the proposed model and simulation results are presented in Section IV, and finally, the conclusion is presented in Section V.

## II. PROBLEM FORMULATION

### A. Constraints

The DG sizing and placement is done for a predefined number of DG units, that is  $N^{DG}$ . The constraints and the fitness function are expressed as follow:

**A.1. Power Balance Constraints:** The power flow equations to be satisfied for each sizing and placement scheme are as follows:

$$\sum_N P_i^{DG} = P_i + P_i^D \quad (1)$$

$$\sum_N Q_i^{DG} = Q_i + Q_i^D \quad (2)$$

$$P_i = V_i \sum_{j=1}^{N_{BUS}} Y_{ij} V_j \cos(\delta_i - \delta_j - \theta_{ij}) \quad (3)$$

$$Q_i = V_i \sum_{j=1}^{N_{BUS}} Y_{ij} V_j \sin(\delta_i - \delta_j - \theta_{ij}) \quad (4)$$

**A.2. Voltage Constraints:** The voltage magnitude of each bus should be kept between operation limits, as follows:

$$V_i^{\min} \leq V_i \leq V_i^{\max} \quad (5)$$

**A.3. Operating Limits of DG Units:** DG units should be operated considering the limits of their primary resources, that is:

$$P_{\min}^{DG} \leq P_i^{DG} \leq P_{\max}^{DG} \quad (6)$$

**A.4. Thermal Constraints:** Thermal limit of distribution lines for the network can be stated as follow:

$$|S_i| \leq |S_i^{\max}| \quad (7)$$

### B. Fitness Function

The proposed scheme is applied to minimize the objective function which is the sum of three factors, namely, the desired network power loss reduction, the desired voltage regulation and the desired voltage stability. Each one of these three factors is separately analyzed to form the fitness function.

**B.1. Power Balance Constraints:** There are different schemes to study the effect of loss reduction. One of the suitable models is stated as follow [11]:

$$\chi_1 = \sum_{i=2}^{N_{BUS}} (P_i - P_i^D - V_i V_j Y_{ij} \cos(\delta_i - \delta_j + \theta_{ij})) \quad (8)$$

**B.2. Voltage Profile Criterion:** There are different schemes to study the effect of loss reduction. One of the suitable models is stated as follow [11]:

$$\chi_2 = \sum_{i=1}^{N_{BUS}} (V_i - V_{BASE})^2 \quad (9)$$

**B.3. Voltage Stability Criterion:** The voltage stability index behavior is used so as to identify the buses experiencing large voltage drops to apply remedial actions. The index of voltage stability for distribution network will be changed by connecting distributed generations to network [12]. One of the appropriate models to evaluate this index is presented in [13], as follow:

$$\chi_3 = \left( \frac{1}{SI(j)} \right) ; \quad j = 2, 3, \dots, N_{BUS} \quad (10)$$

where:

$$SI(j) = (V_i)^4 - 4[P_N(j)R_{ij} + Q_N(j)X_{ij}](V_i)^2 - 4[P_N(j)R_{ij} + Q_N(j)X_{ij}]^2 \quad (11)$$

For stable operation of the radial distribution systems  $SI(j)$  must be greater than 0 for  $j=2, 3, \dots, N_{BUS}$ . Taking into account the Equations (8) to (11), the fitness function (FF) can be consequently expressed as follows:

$$FF = \left( (\lambda_1 + \alpha_1 \lambda_2 + \alpha_2 \lambda_3) + \gamma_1 \sum_{i=1}^{N^{DG}} (\max(V_i - V_i^{\max})) + \max(V_i^{\min} - V_i) + \gamma_2 \sum_{i=1}^{N_{BUS}-1} \max(S_i - S_i^{\max}) \right) \quad (12)$$

where  $\alpha_1, \alpha_2, \gamma_1, \gamma_2$  are penalty coefficients which are considered experimentally 0.33, 0.3, 0.6 and 0.36, respectively. The main goal is to minimize the FF, as follow:

minimize  $\{FF\}$   
subject to: 1 to 7

## III. HURISTIC OPTIMIZATON METHOD

### A. Strength Pareto Evolutionary Algorithm

One of the most successful multi-objective optimization approaches is the SPEA [14] which is based on Pareto optimality concept.

### B. Definition

Concept of Pareto optimality can be described mathematically as below:

The vector  $a$  in the search space dominates vector  $b$  if

$$\forall_i \in \{1, 2, \dots, k\} : f_i(a) \geq f_i(b)$$

$$\exists_j \in \{1, 2, \dots, k\} : f_j(a) > f_j(b) \quad (13)$$

If at least one vector dominates  $b$ , then  $b$  is considered dominated vector, otherwise it is called non-dominated. Each non-dominated solution is regarded optimal in the sense of Pareto or called Pareto optimal.

Obviously, any Pareto optimal solution is comparatively the most optimal one in terms of at least one of the objective functions. The set of all non-dominated solutions is called Pareto Optimal Set (POS) and the set of the corresponding values of the objective functions is called Pareto Optimal Front (POF) or simply Pareto front.

The SPEA which takes benefits from many features of some other approaches is used in this paper. Figure 1 shows a flowchart of the approach which includes the following major steps [14]:

Step 1. Generate an initial population  $P$  and create the empty external non-dominated set  $P'$ .

Step 2. Paste non-dominated members of  $P$  into  $P'$ .

Step 3. Remove all solutions within  $P'$  covered by any other members of  $P'$ .

Step 4. If the number of externally stored non-dominated solutions exceeds a given maximum  $N'$ , prune  $P'$  by means of clustering.

Step 5. Calculate the fitness of all individuals in  $P$  and  $P'$ .

Step 6. Use binary tournament selection with replacement and select individuals from  $P$  and  $P'$  until the mating pool is filled.

Step 7. Apply crossover and mutation operators as usual.

Step 8. If the maximum number of generations is reached, then stop, else go to step 2.

Fitness evaluation is also performed in two steps. First, the individuals in the external non-dominated set  $P'$  are ranked. Then, the individuals in the population  $P$  are evaluated. For more details, refer to [14].

### C. Chaotic Optimization Algorithm

Chaos often exists in the non-linear systems. It is a kind of highly unstable motion of the deterministic systems in finite phase space. An essential feature of the chaotic systems is that small changes in the parameters or the starting values for the data lead to the vastly different future behaviors, such as stable fixed points, periodic oscillations, bifurcations, and ergodicity. This sensitive dependence on the initial conditions is generally exhibited by systems containing multiple elements with non-linear interactions, particularly when the system is forced and dissipative. Sensitive dependence on the initial conditions is not only observed in the complex systems, but even in the simplest logistic equation [15].

The application of the chaotic sequences can be an interesting alternative to provide the search diversity in an optimization procedure. Due to the non-repetition of the chaos, it can carry out overall searches at higher speeds than stochastic ergodic searches that depend on the probabilities. The design of approaches to improve the convergence of the chaotic optimization is a challenging issue. A novel chaotic approach is proposed here based on the Lozi map [16]. The simple philosophy of the COA includes two main steps: firstly mapping from the chaotic space to the solution space, and then searching optimal regions using chaotic dynamics instead of random searches [17, 18]. This chaotic map involves also nondifferentiable functions which makes difficult the modeling of the associate time series. The Lozi map is given by [19]:

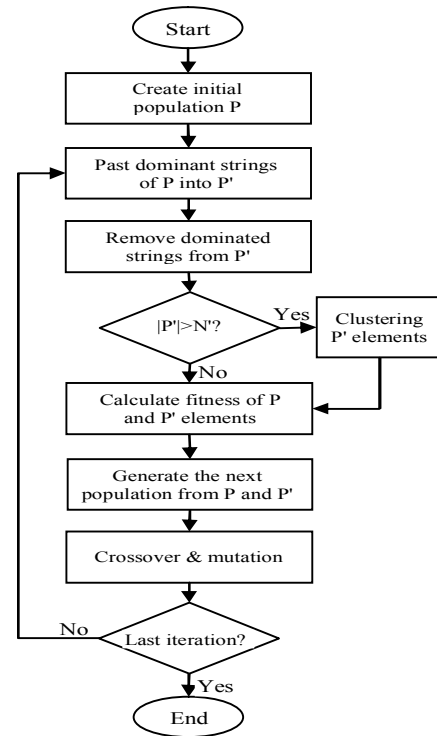

Figure 1. Strength Pareto flowchart

$$y_1(k) = 1 - a \times |y_1(k-1)| + y(k-1) \quad (14)$$

$$y(k) = b \times y_1(k-1) \quad (15)$$

$$z(k) = \frac{y(k) - \alpha}{\beta - \alpha} \quad (16)$$

where  $k$  is the iteration number. In this work, the values of  $y$  are normalized in the range  $[0, 1]$  to each decision variable in  $n$ -dimensional space of optimization problem. Therefore,  $y_1 = [-0.6418, 0.6716]$  and  $[\alpha, \beta] = (-0.6418, 0.6716)$ . The parameters used in this work are  $a = 1.7$  and  $b = 0.5$ , suggested by Caponetto et al. [21].

### D. Genetic Algorithm

It is well known that GAs work according to the mechanism of natural selection - stronger individuals is likely to be the winners in a competitive environment. In practical applications, each individual is codified into a chromosome consisting of genes, each representing a characteristic of one individual.

For identification of the unknown parameters of a model, parameters are regarded as the genes of a chromosome, and a positive value, generally known as the fitness value, is used to reflect the degree of goodness of the chromosome [20, 21]. Typically, a chromosome is structured by a string of values in binary form, which the mutation operator can operate on any one of the bits, and the crossover operator can operate on any boundary of each two bits in the string. Since in our problem the parameters are real numbers, a real coded GA is used, in which the chromosome is defined as an array of real numbers with the mutation and crossover operators. Here, the mutation can change the value of a real number randomly, and the crossover can take place only at the boundary of two real numbers. More details of proposed GA are shown in Figure 2.

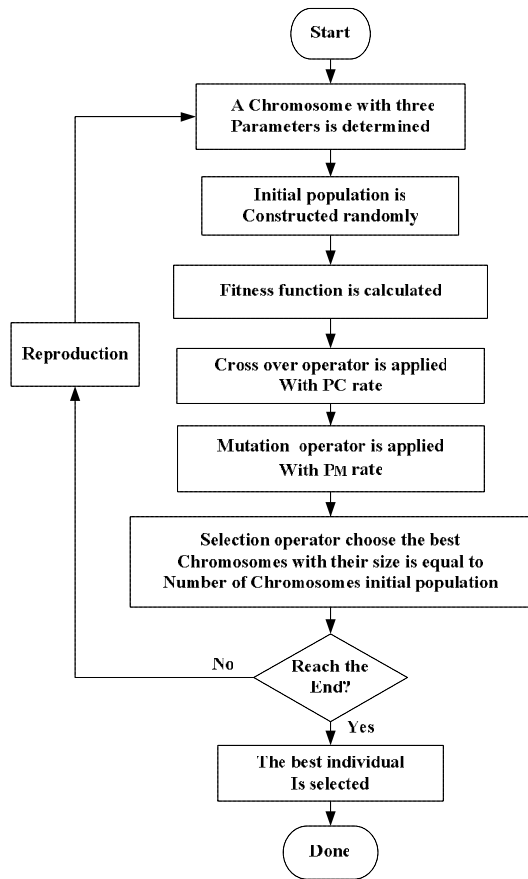

Figure 2. GA flowchart

IV. SIMULATION RESULT

A. Case Study

The proposed SPEA methodology is applied to two different distribution systems to illustrate its strong performance. The first distribution network under study is the 33 bus radial system which has 32 sections with the total load of 3.72 MW, 2.3 MVar as depicted in Figure 3a. The original total real power loss and reactive power loss in the system are 0.211 MW and 0.143 MVar, respectively [22]. The second system is a 69 bus radial distribution system as illustrated in Figure 3b. The technical data of this network can be found in [23].

B. Determination of Parameters for SPEA

The proposed SPEA methodology is programmed in Matlab running on an Intel W Core TM2 Duo Processor T5300 (1.73 GHz) PC with 1 GB RAM. It is applied on 33 and 69 bus systems to demonstrate its abilities. The effect of SPEA parameters on average fitness function (among 100 trials) is investigated. The colony size ( $N_c$ ) tried was 100. Hundred independent trials have been made with 100 iterations per trial. The performance of the SPEA also depends on the number of colonies. The parameters of SPEA are selected based on the average fitness function. After a number of careful experimentation, following optimum values of SPEA parameters have finally been settled as furnished in Table 2. In addition, Table 1 shows the optimum values obtained for COA and GA parameters.

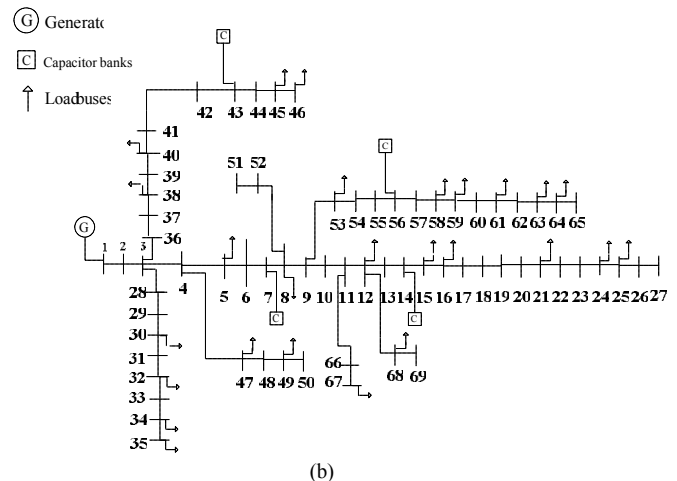
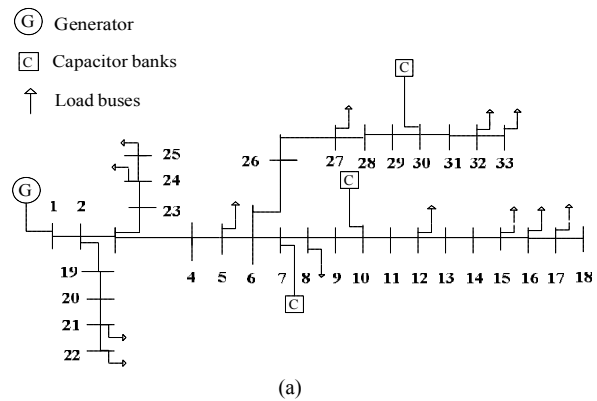

Figure 3. Single line diagrams, (a) 33-bus system, (b) 69-bus system

Table 1. SPEA, COA and GA simulation parameters

Method	Parameters
SPEA	$N_c = 100$ ; Mutation = 0.036; Length of the Chromosome = 5 for each variable; Recombination: single-point crossover
COA	$N_c = 100$ ; $K = 2$ ; $a = 1.7$ ; $b = 0.5$
GA	$N_c = 100$ ; Normalized geometric selection; Simple Xover; Binary mutation

C. Comparing Result

The results for optimal sitting and sizing problems of distributed generation are described in Table 2. The SPEA results are compared with the results obtained by COA and GA separately (the location, DG size, the real power losses, voltage profile and the voltage stability).

Execution time complexity of each optimization method is very important for its application to real systems. One of the main advantages of the proposed method is that the convergence of SPEA algorithm is faster and less time consuming as compared to the case where either method is applied alone. Because the proposed algorithm (SPEA) provides the correct answers with high accuracy in the initial iterations which make the responding time of this algorithm extremely fast. The superiority of proposed method in better converging is depicted in Figure 4.

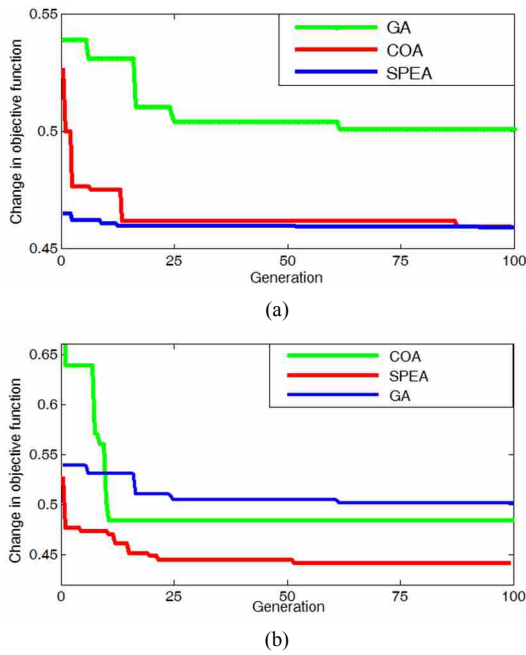

Figure 4. Variations of objective function, (a) 33-bus system, (b) 69-bus system

Table 2. DG location and capacities for three DG units

Bus	DG Size (MW)					
	33-Bus System			69-Bus System		
	SPEA	COA	GA	SPEA	COA	GA
5	-	1.0664	-	-	-	-
12	-	0.8894	-	-	-	-
13	0.7771	-	-	-	-	-
15	1.1770	-	0.8177	-	-	-
22	-	-	-	-	-	0.6434
25	-	-	-	-	-	-
28	-	-	0.6632	-	-	-
30	-	-	1.1297	-	-	-
31	1.0993	1.1944	-	-	-	-
54	-	-	-	-	-	1.1003
60	-	-	-	0.9080	0.7800	-
61	-	-	-	0.8784	-	1.1065
63	-	-	-	-	0.8615	-
67	-	-	-	-	1.1684	-
68	-	-	-	1.0806	-	-
$\chi_1$	0.0928	0.0940	0.1005	0.0789	0.0817	0.0820
$\chi_2$	0.0032	0.0028	0.0058	0.0047	.0054	0.0077
$\chi_3$	1.0169	1.0236	1.0302	0.9914	0.9877	1.0311

The voltage profile and the voltage stability index for both systems are depicted in Figures 5 and 6, respectively. The results show different voltage levels during the pre and post installation of DG. As it can be seen from the Figure 5, the voltage levels at all nodes for radial distribution systems have improved. Additionally, the weakness of voltage stability indexes for all nodes in the radial distribution system before installing the DG is vivid. As shown in Figure 6, after installing the DG the stability indexes at the nodes for distribution systems are improved. As understood from Table 2, the average value of fitness function for SPEA method is less than other analyzed methods and also it has lower standard deviation. This means that the SPEA is more robust compared to other heuristic methods such as COA, GA. The output variances for GA and COA are at 0.07734 and 0.01997 respectively, but it has found to be almost at zero

for the SPEA method. Hence, having zero variance is indicating that the proposed method is preferred in comparison with the other two. The above-mentioned is drawn in Figure 7.

### V. CONCLUSIONS

In this paper a new technique is proposed to solve location and capacity problems for DG. The proposed strength Pareto evolutionary algorithm (SPEA) is implemented on the 33 and 69 bus systems to minimize the losses, to increase the voltage stability and to improve the voltage regulation index. The obtained results are compared to the results from the other two, COA and GA, and advantages and disadvantages are discussed. Results demonstrate that the proposed scheme is better due to negligible value for the variances as well as being able to find the best optimized solution for the system. Taking into account active power losses, reactive power and the value for objective function, it can be deduced that the SPEA reveals a higher ability in finding optimum solutions.

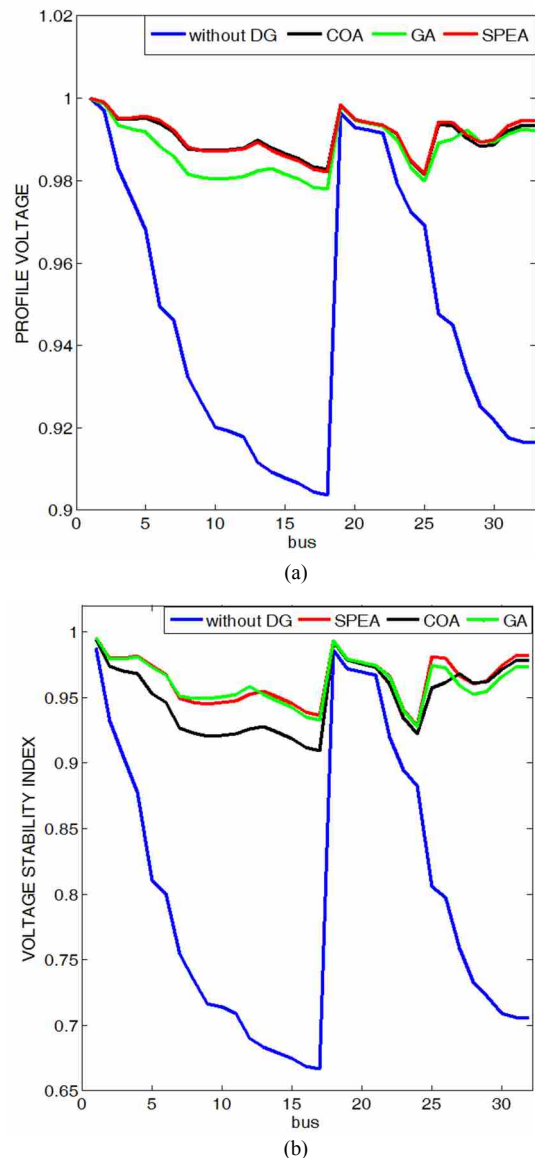
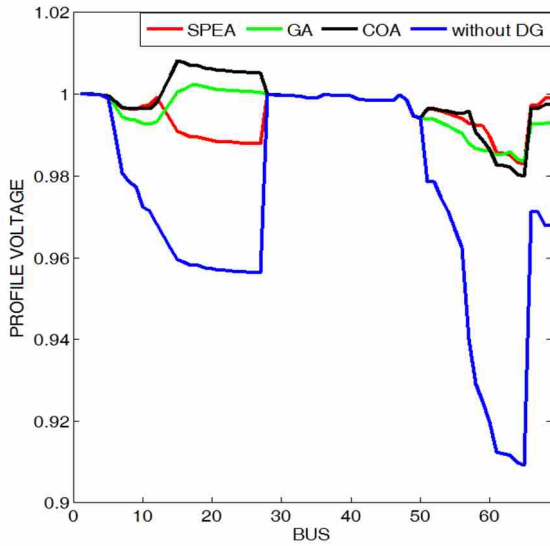
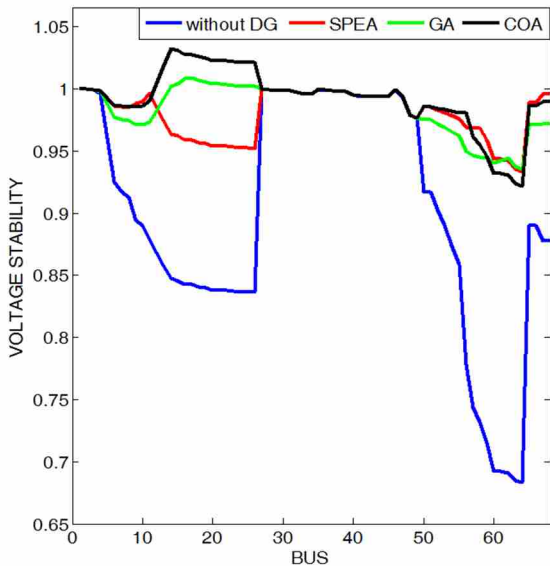

Figure 5. Voltage profiles, (a) 33-bus system, (b) 69-bus system



(a)



(b)

Figure 6. Voltage stability index, (a) 33-bus system, (b) 69-bus system

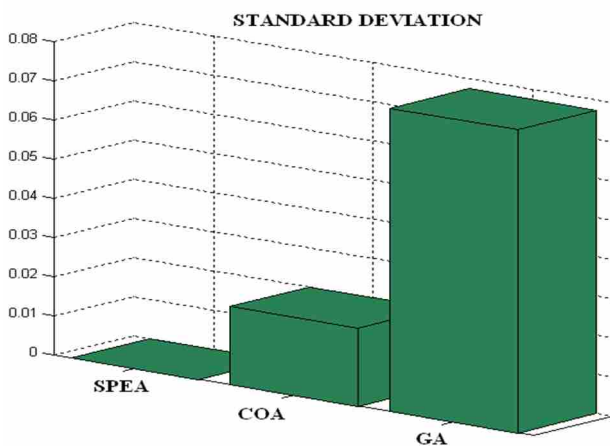

Figure 7. Variances of objective function

### NOMENCLATURES

- $P_i$ : Active power injected to bus  $i$
- $P_i^D$ : Active power demand in bus  $i$
- $P_i^{DG}$ : Active power injected by a DG in bus  $i$
- $Q_i$ : Reactive power injected to bus  $i$
- $Q_i^D$ : Reactive power demand in bus  $i$
- $Q_i^{DG}$ : Reactive power injected by a DG in bus  $i$
- $V_i$ : Voltage magnitude in bus  $i$
- $V_j$ : Voltage magnitude in bus  $j$
- $Y_{ij}$ : The line admittance between bus  $i$  and  $j$
- $\delta_i$ : Voltage angle in bus  $i$
- $\delta_j$ : Voltage angle in bus  $j$
- $\theta_{ij}$ : Admittance angle between bus  $i$  and  $j$
- $P_{max}^{DG}$ : Maximum operating limit of a DG
- $P_{min}^{DG}$ : Minimum operating limit of a DG
- $V_i^{min}$ : Minimum operation limit of voltage
- $V_i^{max}$ : Maximum operation limit of voltage
- $N_{DG}$ : The total number of all installed DGs
- $N_{BUS}$ : Number of buses in the network
- $\chi_1$ : Real power loss of the network
- $\chi_2$ : Voltage profile of the network
- $\chi_3$ : Voltage stability index of the network
- $S_i$ : Apparent power at bus  $i$
- $S_i^{max}$ : Maximum operating of apparent power at bus  $i$
- $SI(j)$ : Voltage stability index of node  $j$
- $FF$ : Fitness function
- $i, j$ : Bus

### REFERENCES

- [1] R.C. Dugan, M.F. McGranaghan, S. Santoso, H.W. Beaty, "Electrical Power Systems Quality", 2nd Edition, McGraw-Hill Co., 2003.
- [2] R.C. Dugan, T.E. McDermott, G.J. Ball, "Planning for Distributed Generation", IEEE Industry Applications Magazine, pp. 80-88, March/April 2001.
- [3] M. Sedighzadeh, A. Rezaazadeh, "Using Genetic Algorithm for Distributed Generation Allocation to Reduce Losses and Improve Voltage Profile," Proceedings of World Academy of Science, Engineering and Technology (CESSE2008), Cairo, Egypt, Vol. 27, ISSN 1307-6884, pp. 251-256, February 6-8, 2008.
- [4] E.B. Cano, "Using Fuzzy Optimization for Distributed Generation Allocation", Power Engineering, Large System Conference, Vol. 27, pp. 251-256, 10-12 October 2007.
- [5] M.A. Kashem, L. Adt, M. Negnevitsky, G. Ledwich, "Distributed Generation for Minimization of Power Losses in Distribution Systems", IEEE Power Engineering Society General Meeting, pp. 1-8, 2008.
- [6] M. Golshan, S. Arefifar, "Optimal Allocation of Distributed Generation and Reactive Sources Considering Tap Positions of Voltage Regulators as Control Variables", European Transactions on Electrical Power System, Vol. 17, 2007.
- [7] C. Wang, M.H. Nahrir, "Analytical Approaches for Optimal Placement of Distributed Generation Sources in Power Systems", IEEE Transactions on Power System, Vol. 19, No. 4, pp. 2068-2076, November 2004.
- [8] E.B. Cano, "Using Fuzzy Optimization for Distributed Generation Allocation", Power Engineering,

Large System Conference, pp. 251-256, 10-12 October 2008.

[9] H. Shayeghi, A. Ghasemi, "Application of MOPSO for Economic Load Dispatch Solution with Transmission Losses", International Journal on Technical and Physical Problems of Engineering (IJTPE), Issue 10, Vol. 4, No. 1, pp. 27-34, March 2012.

[10] K. Nekooei, M.M. Farsangi, H. Nezamabadi-pour, "An Improved Harmony Search Approach to Economic Dispatch", International Journal on Technical and Physical Problems of Engineering (IJTPE), Issue 8, Vol. 3, No. 3, pp. 25-31, September 2011.

[11] M.H. Moradi, M. Abedini, "A Combination of Genetic Algorithm and Particle Swarm Optimization for Optimal DG Location and Sizing in Distribution Systems", International Journal Electrical Power and Energy System, Vol. 34, pp. 66-74, 2012.

[12] M. Charkravorty, "Voltage Stability Analysis of Radial Distribution Networks", International Journal on Electrical Power and Energy System, Vol. 23, No. 2, pp. 129-135, 2001.

[13] P.N. Vovos, J.W. Bialek, "Direct Incorporation of Fault Level Constraints in Optimal Power Flow as a Tool for Network Capacity Analysis", IEEE Transactions on Power System, Vol. 20, No. 4, pp. 2125-2134, 2005.

[14] E. Zitzler, L. Thiele, "Multiobjective Evolutionary Algorithms: A Comparative Case Study and the Strength Pareto Approach", IEEE Transactions on Evolutionary Computation, Vol. 3, pp. 257-271, 1999.

[15] B. Liu, L. Wang, Y.H. Jin, F. Tang, D.X. Huang, "Improved Particle Swarm Optimization Combined with Chaos", Chaos, Solutions and Fractals, Vol. 25, pp. 1261-1271, 2005.

[16] L.D.S. Coelho, "Tuning of PID Controller for an Automatic Regulator Voltage System Using Chaotic Optimization Approach", Chaos, Solutions and Fractals, Vol. 39, No. 4, pp. 1504-1514, 2009.

[17] D. Yang, G. Li, G. Cheng, "On the Efficiency of the Chaos Optimization Algorithms for Global Optimization", Chaos, Solutions and Fractals, Vol. 34, pp. 1366-1375, 2007.

[18] X.F. Yan, D.Z. Chen, S.X. Hu, "Chaos Genetic Algorithms for Optimizing the Operating Conditions Based on RBF-PLS Model", Computers and Chemical Engineering, pp. 1393-1404, 2003.

[19] R. Caponetto, L. Fortuna, S. Fazzino, M.G. Xibilia, "Chaotic Sequences to Improve the Performance of Evolutionary Algorithms", IEEE Transactions on Evolutionary Computation, Vol. 7, No. 3, pp. 289-304, 2003.

[20] A. Raie, V. Rashtchi, "Using Genetic Algorithm for Detection and Magnitude Determination of Turn Faults in Induction Motor", Electrical Engineering, Vol. 84, No. 3, pp. 275-279, August 2002.

[21] S. Jalilzadeh, M. Azari, "A Novel Approach for PID Designing for Load Frequency Control System", International Review on Modeling and Simulation, Vol. 5, No. 3, pp. 1159-1164, June 2012.

[22] M. Baran, F. Wu, "Optimal Sizing of Capacitor Placed on Radial Distribution Systems", IEEE Transactions on Power Delivery, Vol. 4, No. 1, pp. 735-743, 1989.

[23] H. Abdellatif, Z. Khaled, "Efficient Load Flow Method for Radial Distribution Feeders", Journal of Applied Science, Vol. 6, No. 13, pp. 2741-2748, 2006.

## BIOGRAPHIES



**Saeid Jalizadeh** was born in Salmas, Iran in 1962. He received his B.Sc. and M.Sc. degree both in Electrical Engineering from Tabriz University, Tabriz, Iran in 1986 and 1989, respectively. He received Ph.D. degree in Electrical Engineering from Iran University of Science and Technology, Tehran, Iran in 2005. Currently, he is an Assistant Professor at Technical Engineering Department of University of Zanjan, Zanjan, Iran. He is the author of more than 60 journal and conference papers. His research interests are dynamic stability, power market, and renewable energy in power system, power system contingency analysis and power system planning. He is a member of the institute of electrical and electronics engineers (IEEE).



**Mohsen Darabian** received his B.Sc. degree in Electrical Engineering from Abhar Branch, Islamic Azad University, Abhar, Iran in 2010. He is currently a M.Sc. student at Department of Power Engineering, University of Zanjan, Zanjan, Iran. His research interests include application of intelligent methods in power systems, distributed generation modeling, power electronic, FACTS, power quality and power system dynamics.



**Mehdi Azari** was born in Zanjan, Iran in 1986. He received his B.Sc. degree in Electrical Engineering from University of Zanjan, Zanjan, Iran in 2008. He is currently a M.Sc. student at Department of Electrical Engineering, University of Zanjan, Zanjan, Iran. His research interests include application of intelligent methods in power systems, distributed generation modeling, power system.